

Fasteners Assembly Instructions for MNT-0815

Applying for products:

0055 MNT-0815-PC-SH / 0055 MNT-0815-EXP-SH

0085 MNT-0815-PC-3H / 0085 MNT-0815-EXP-3H

Part number	Description	Qty/per set
AC01	Hex Head Bolt M12 x 40mmL x P1.25	6
AC02	Nyloc Nut M12 x P1.25	6
AC03	Steel Nord Lock Washer M12 x 13mmID x 19mmOD x 2.2mmT	6
AC04	Steel Flat Washer M12 x 13mmID x 26mmOD x 2.2mmT	32
AC05	Hex Head Bolt M12 x 60mmL x P1.25 - Haft theard27mm Zinc	4
AC06	Steel Spring Washer M12	4
AC07	Hex Head Bolt M16 x 30mmL x P 2	4
AC08	Steel Flat Washer M16 x 17mmID x 30mmOD x 2.5mmT	4
AC09	Hex Head Bolt M8 x 30mmL x P1.25 (Full thread) - DIN 933	2
AC10	Steel Flat Washer M8 x 8.4mmID x 17mmOD x 2.5mmT	20
AC11	Steel Spring Washer M8	12
AC12	Hex Head Bolt M8 x 25mmL x P 1.25	10
AC13	Nyloc Nut M8 x P1.25	4
AC14	M6 x 12mmL x P1 Steel Hex socket (allen Key) & Domed Head Bolt	8
AC15	Steel Spring Washer M6	8
AC16	Steel Flat Washer M6 x 6.6mmID x 15mmOD x 2mmT	8
AC17	M4 x 15mmL x P0.7 Hex socket (allen Key) & Domed Head Bolt	12
AC18	Steel Flat Washer M4 x 4.3mmID x 9mmOD x 0.8mmT	12
AC19	Nyloc Nut M4 x P0.7	4
AC20	M8 x 16mmL x P1.25 Steel Hex socket (allen Key) & Domed Head Bolt	12
AC21	Hex Head Bolt M8 x 20mmL x P 1.25	4
AC30	Electric Cable Packed	1
AC31	Frog Lights (Pair) with Accessories	1
AC32	Indicator Lights (Pair)	1

GENERAL VIEW

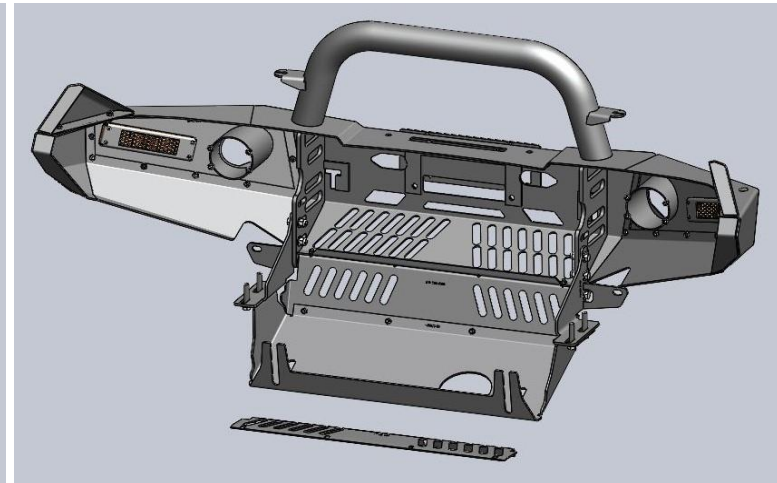
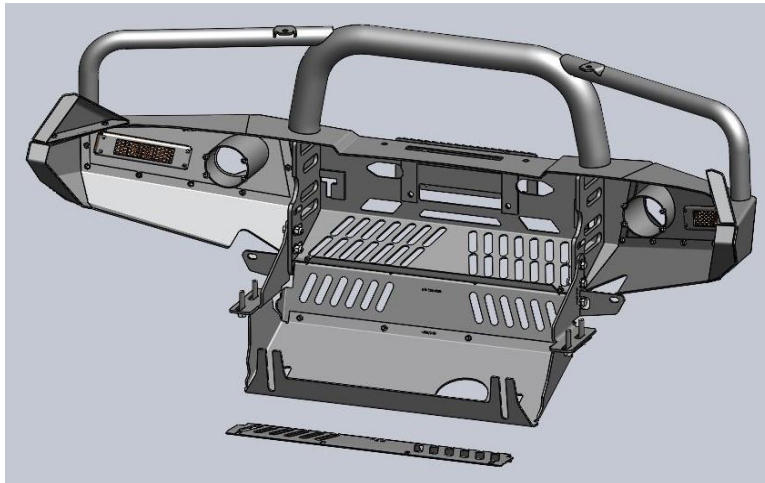
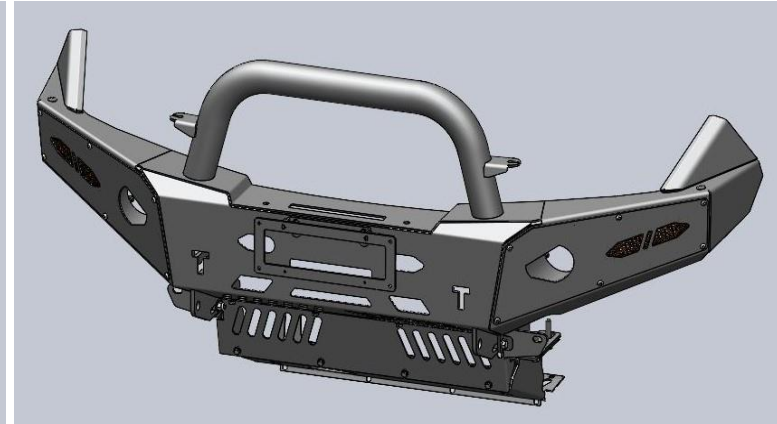
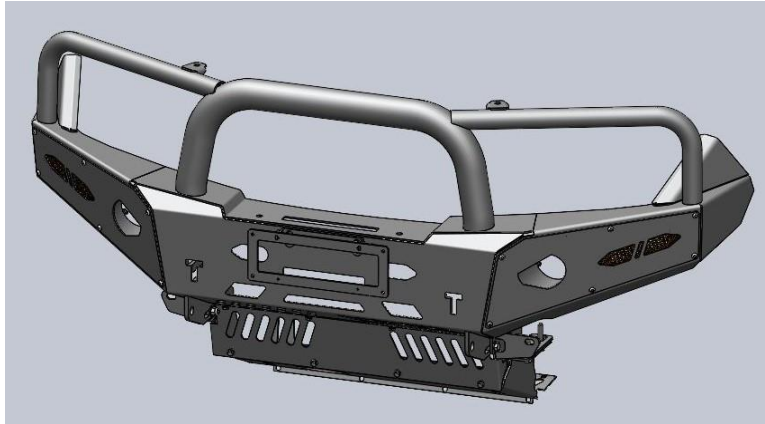

3 HOOP

SINGLE HOOP

WI-004-R2

STEP 1: Install Brackets into the Car, bolted both sides with 4 positions.

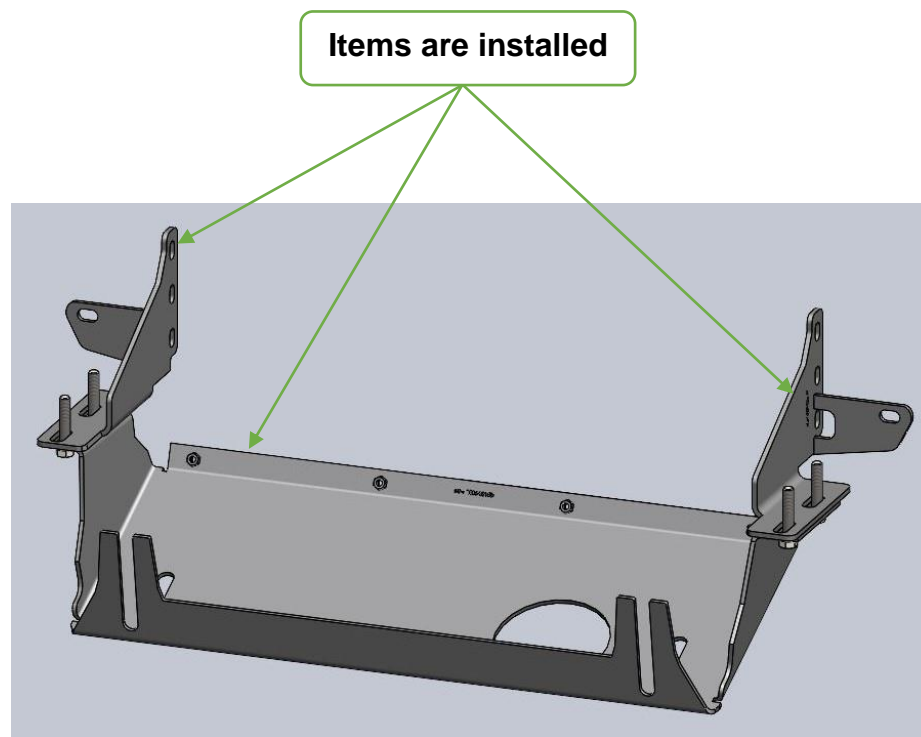
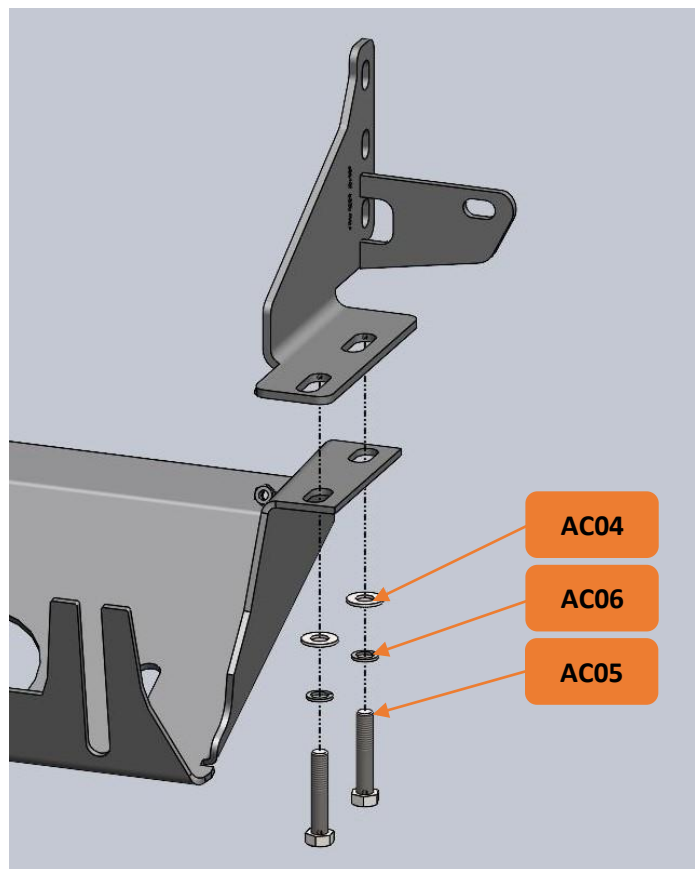

AC04 x 04 pcs : Steel Flat Washer M12 x 13mmID x 26mmOD x 2.2mmT

AC05 x 04 pcs : Hex Head Bolt M12 x 60mmL x P1.25 - Haft theard27mm Zinc

AC06 x 04 pcs : Steel Spring Washer M12

Bolt Tightening Torque: 88(Nm)

WI-004-R2

STEP 2.1: Install Bull Bar Body into the Car, bolted both sides with 6 positions. [Use for Body Lift only]

Note: Install lower 3 bolt holes for Body Lift

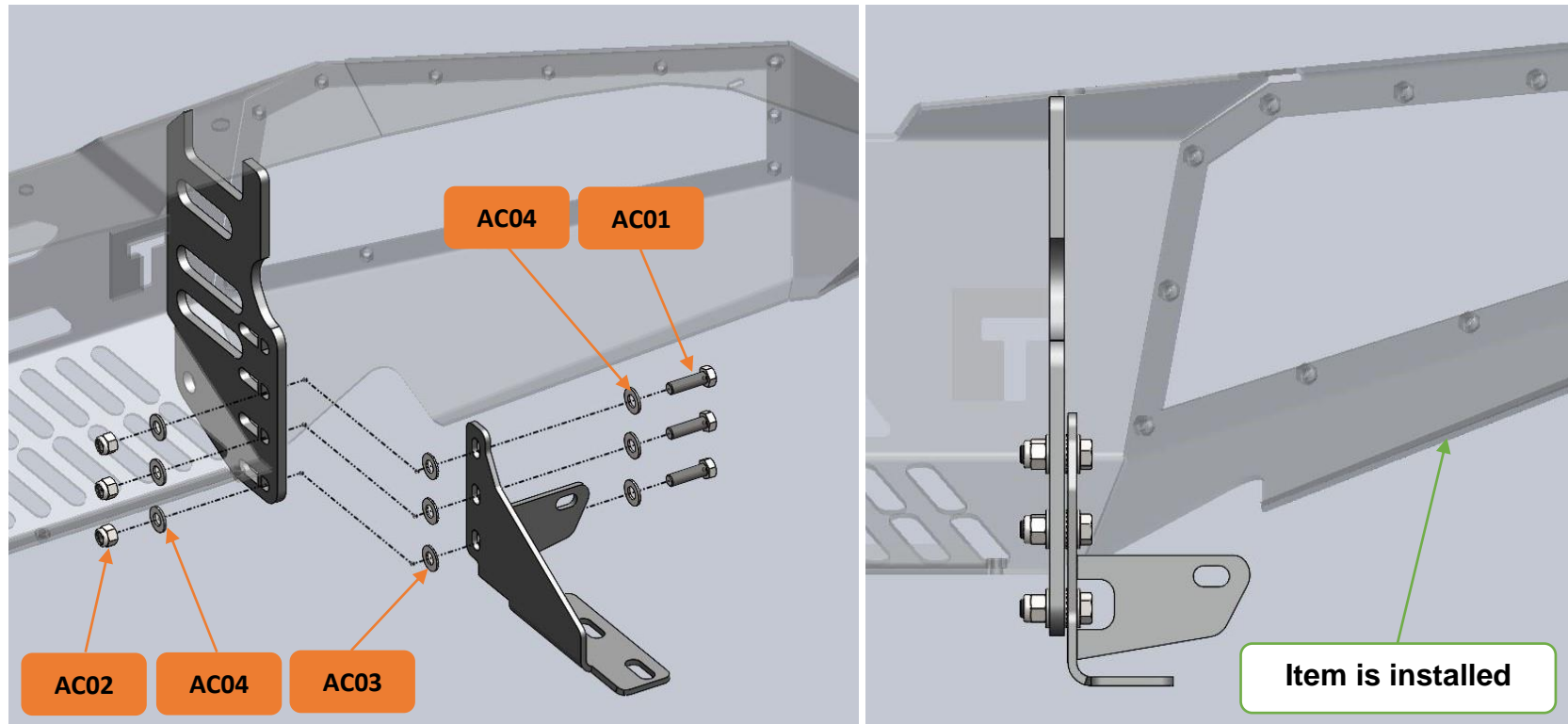

AC01 x 06 pcs : Hex Head Bolt M12 x 40mmL x P1.25

AC02 x 06 pcs : Nyloc Nut M12 x P1.25

AC03 x 06 pcs : Steel Nord Lock Washer M12 x 13mmID x 19mmOD x 2.2mmT

AC04 x 12 pcs : Steel Flat Washer M12 x 13mmID x 26mmOD x 2.2mmT

Bolt Tightening Torque: 88(Nm)

WI-004-R2

STEP 2.2: Install Bull Bar Body into the Car, bolted both sides with 6 positions. **[Use for No Body Lift only]**

Note: Install upper 3 bolt holes for No Body Lift

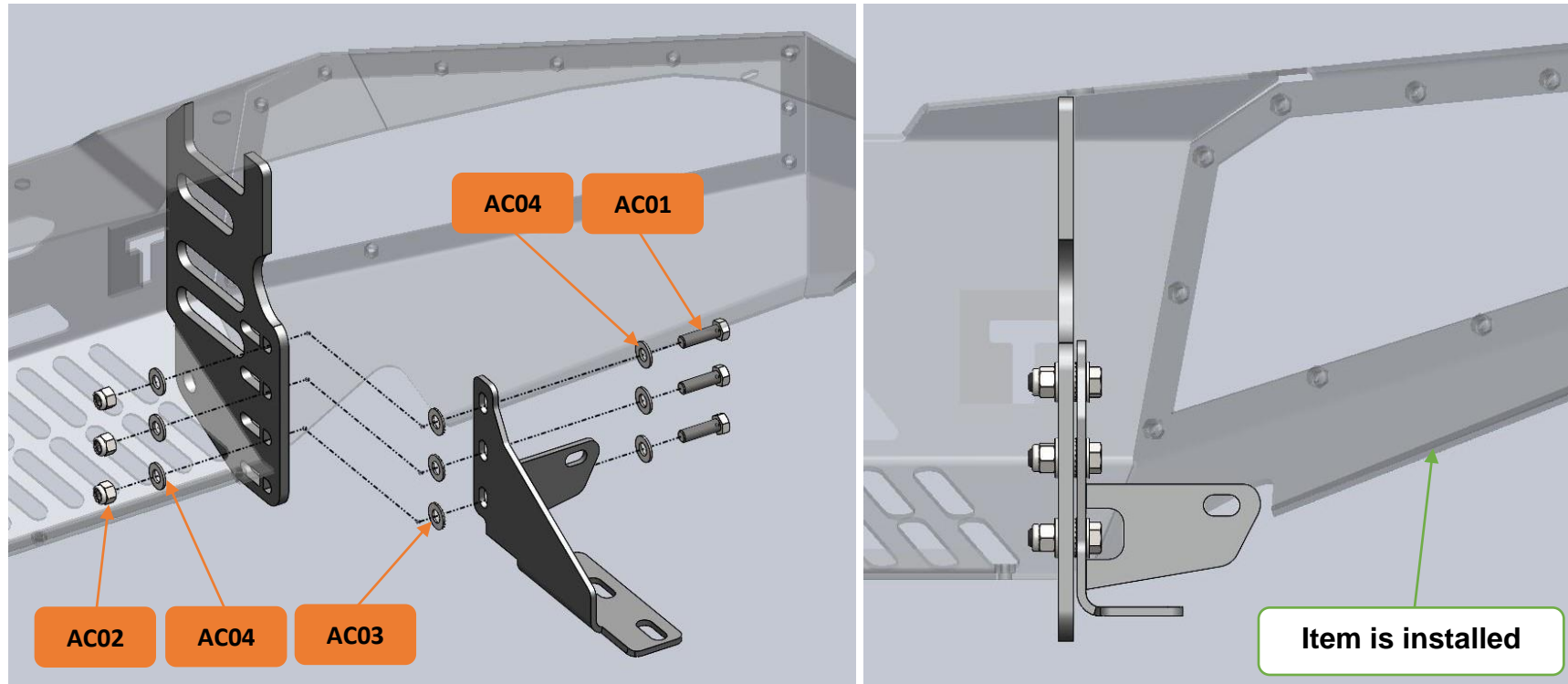

AC01 x 06 pcs : Hex Head Bolt M12 x 40mmL x P1.25

AC02 x 06 pcs : Nyloc Nut M12 x P1.25

AC03 x 06 pcs : Steel Nord Lock Washer M12 x 13mmID x 19mmOD x 2.2mmT

AC04 x 12 pcs : Steel Flat Washer M12 x 13mmID x 26mmOD x 2.2mmT

Bolt Tightening Torque: 88(Nm)

WI-004-R2

STEP 3.1: Install 3 Hoop into the Car, bolted with 4 positions. **[Use for 3 Hoop only]**

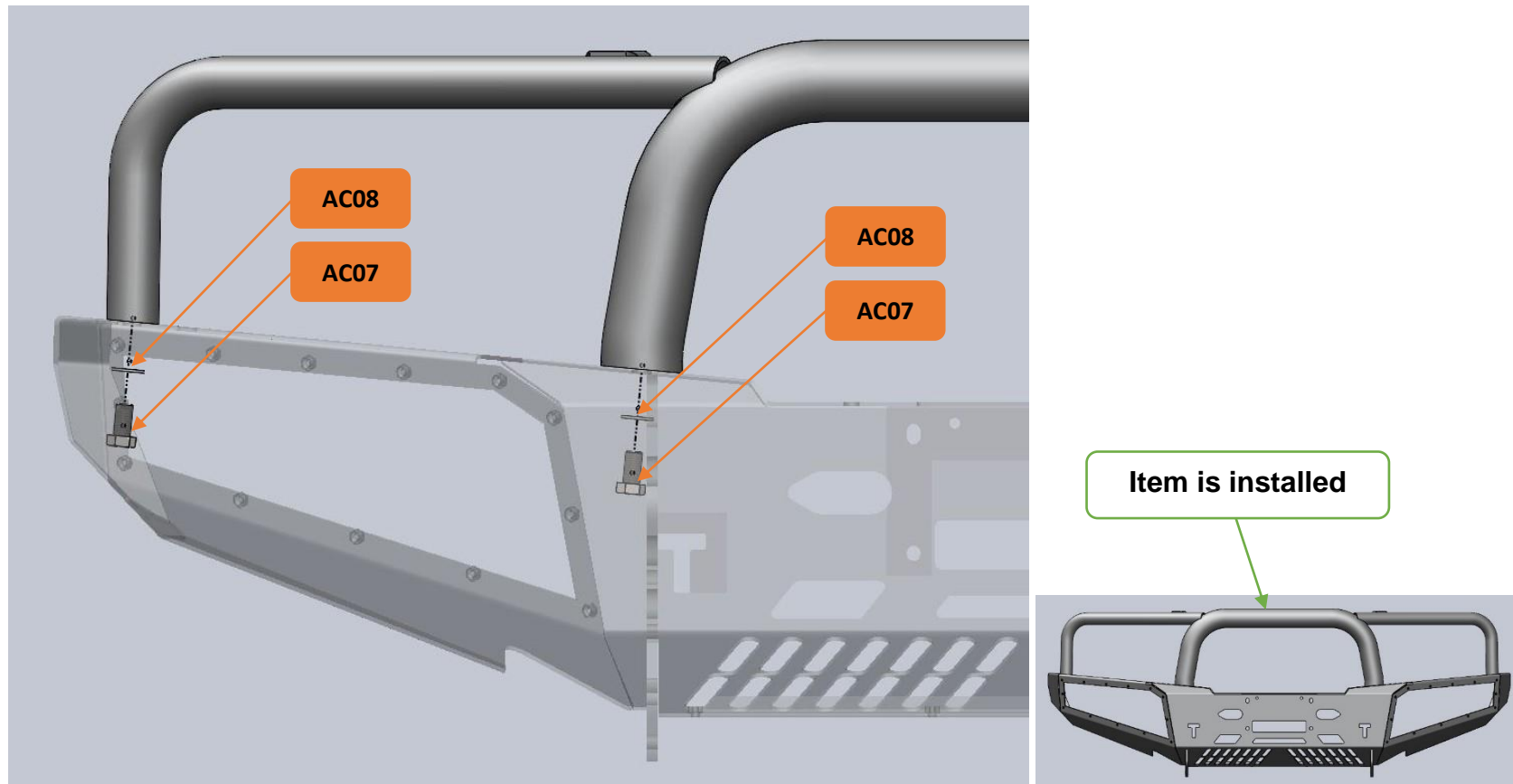

AC07 x 04 pcs : Hex Head Bolt M16 x 30mmL x P 2

AC08 x 04 pcs : Steel Flat Washer M16 x 17mmID x 30mmOD x 2.5mmT

Bolt Tightening Torque: 88(Nm)

WI-004-R2

STEP 3.2: Install Single Hoop & Plastic Cap into the Car, bolted with 4 positions. **[Use for Single Hoop only]**

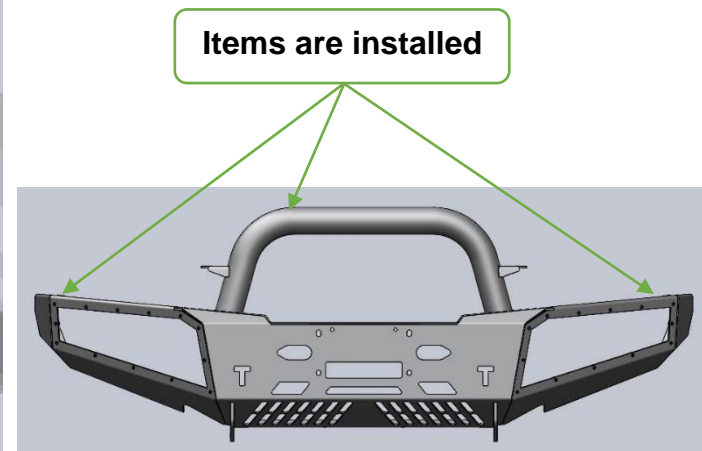
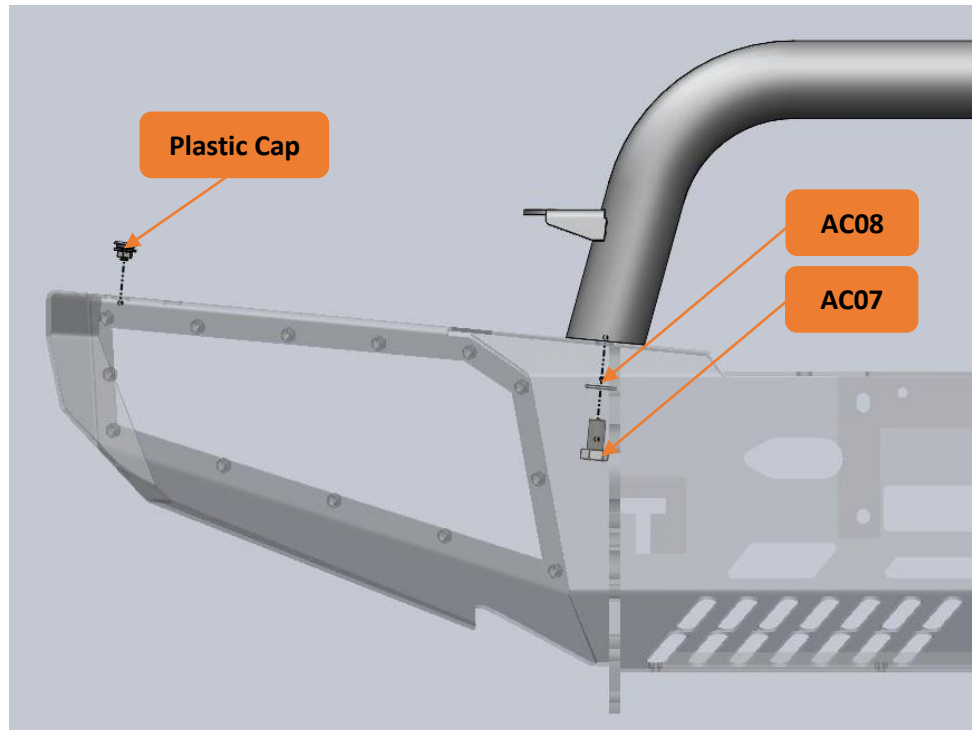

Plastic Cap x 02 pcs

Bolt Tightening Torque: 3(Nm)

AC07 x 02 pcs : Hex Head Bolt M16 x 30mmL x P 2

AC08 x 02 pcs : Steel Flat Washer M16 x 17mmID x 30mmOD x 2.5mmT

Bolt Tightening Torque: 88(Nm)

WI-004-R2

STEP 4.1: Install Bottom Cover Plate into the Bull Bar, bolted with 8 positions. **[Use for Body Lift only]**

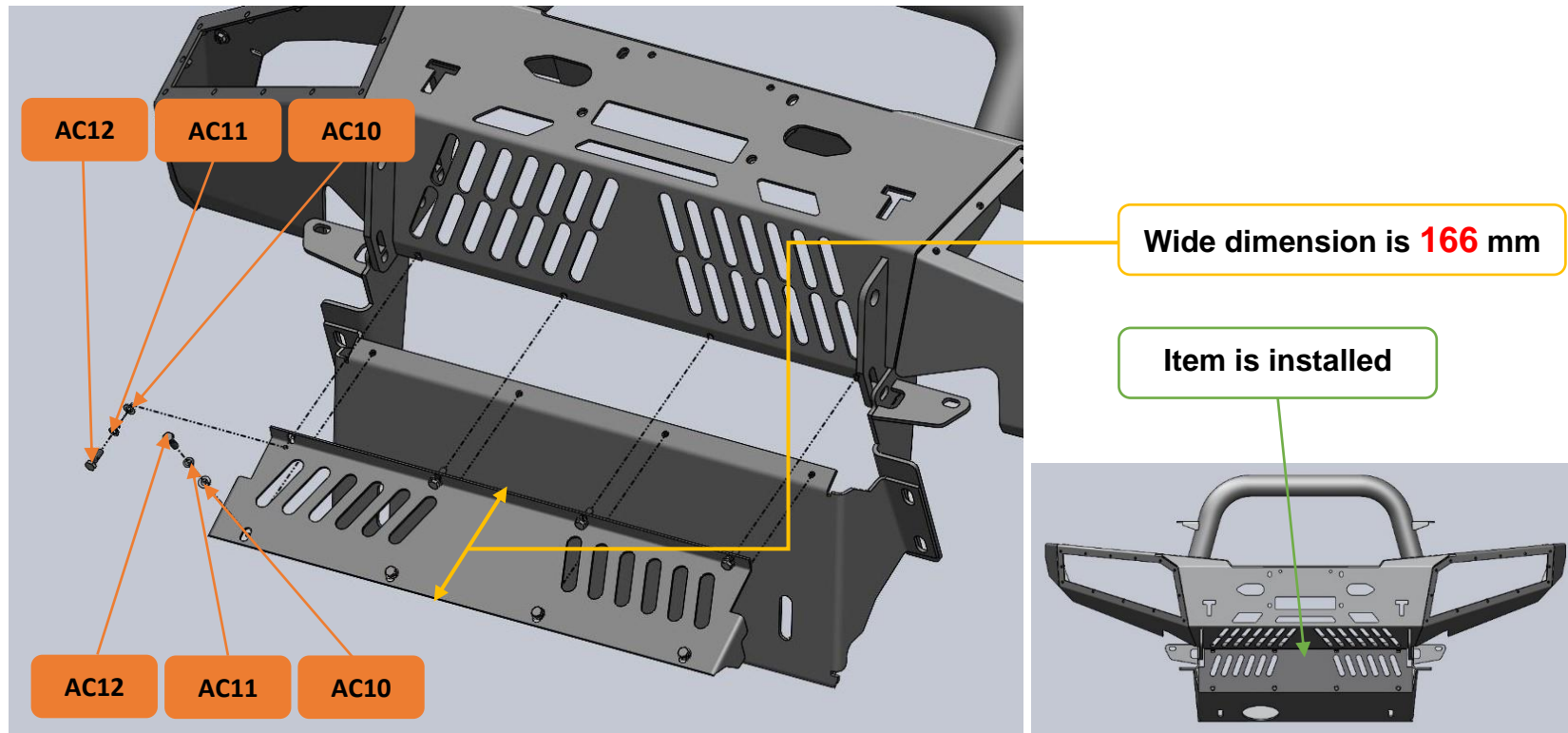

AC10 x 08 pcs : Steel Flat Washer M8 x 8.4mmID x 17mmOD x 2.5mmT

AC11 x 08 pcs : Steel Spring Washer M8

AC12 x 08 pcs : Hex Head Bolt M8 x 25mmL x P 1.25

Bolt Tightening Torque: 24(Nm)

WI-004-R2

STEP 4.2: Install Bottom Cover Plate into the Bull Bar, bolted with 8 positions. **[Use for No Body Lift only]**

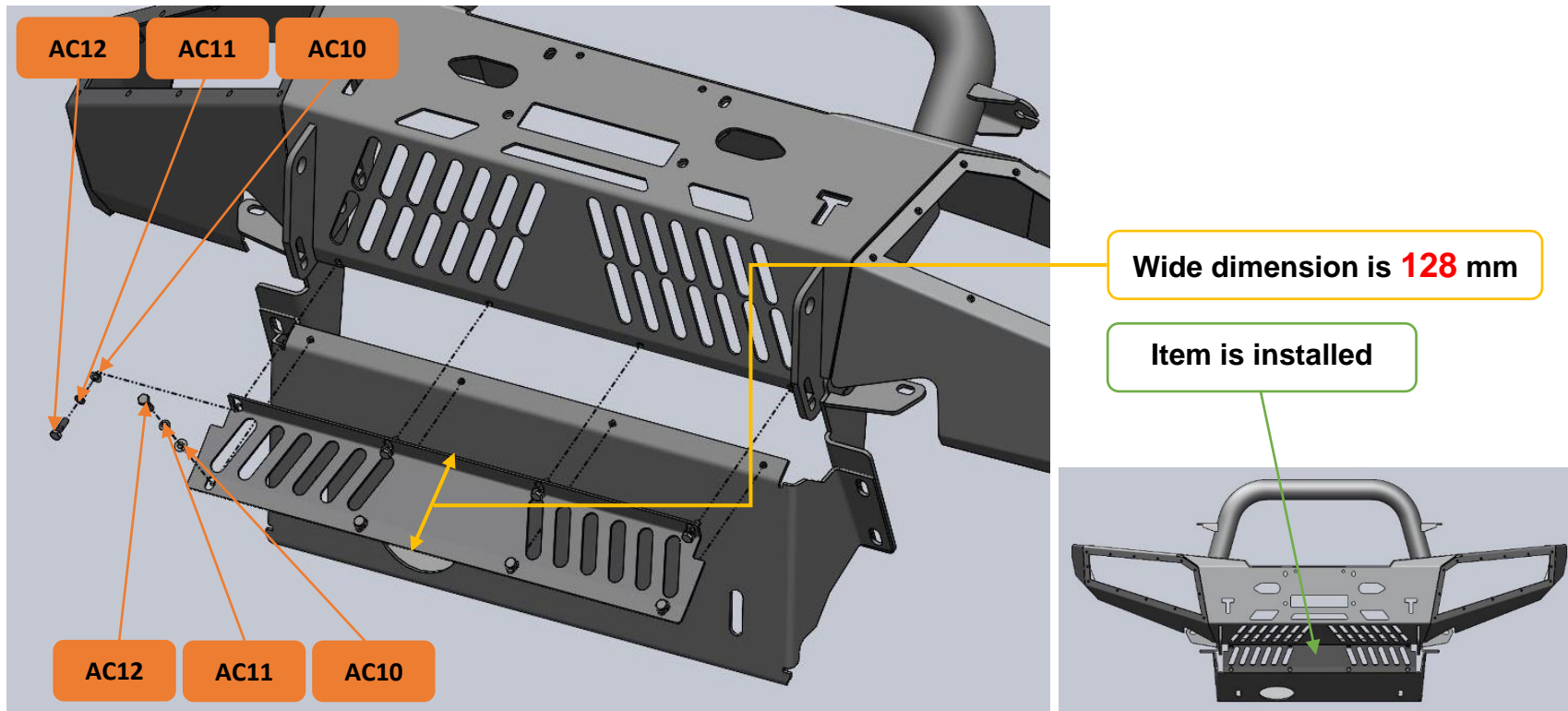

AC10 x 08 pcs : Steel Flat Washer M8 x 8.4mmID x 17mmOD x 2.5mmT

AC11 x 08 pcs : Steel Spring Washer M8

AC12 x 08 pcs : Hex Head Bolt M8 x 25mmL x P 1.25

Bolt Tightening Torque: 24(Nm)

WI-004-R2

STEP 5: Install Infill Plate LH & RH, bolted both side with 4 positions.

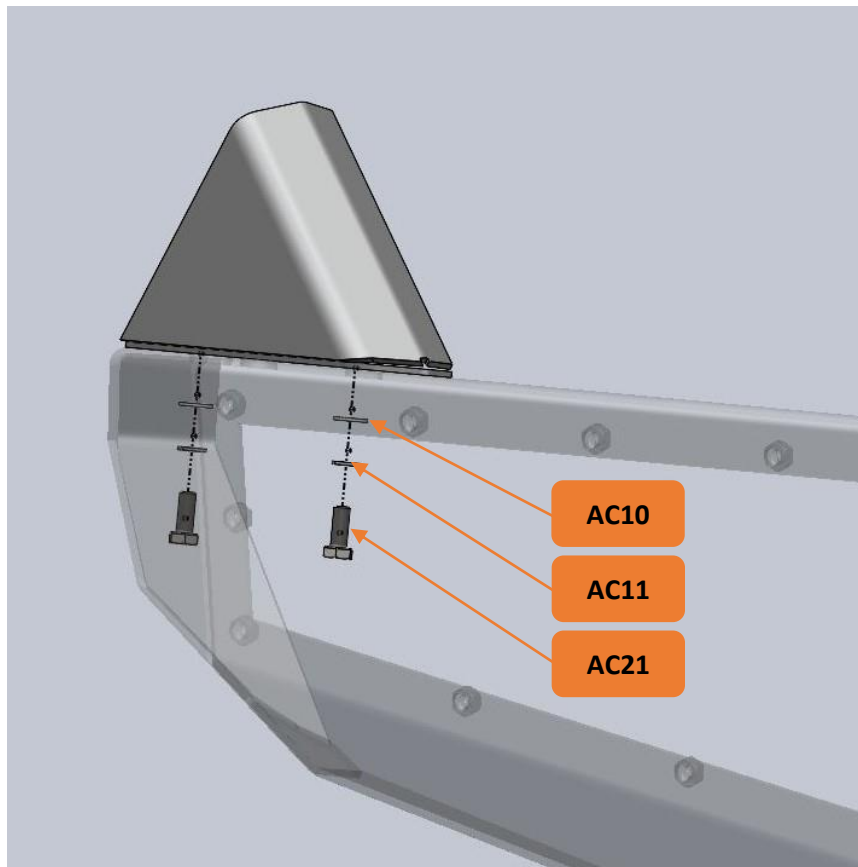

AC10 x 04 pcs : Steel Flat Washer M8 x 8.4mmID x 17mmOD x 2.5mmT

AC11 x 04 pcs : Steel Spring Washer M8

AC21 x 04 pcs : Hex Head Bolt M8 x 20mmL x P 1.25

Bolt Tightening Torque: 24(Nm)

WI-004-R2

STEP 6.1: Install Frog Light into Light Panel LH & RH, bolted both side with 8 positions.

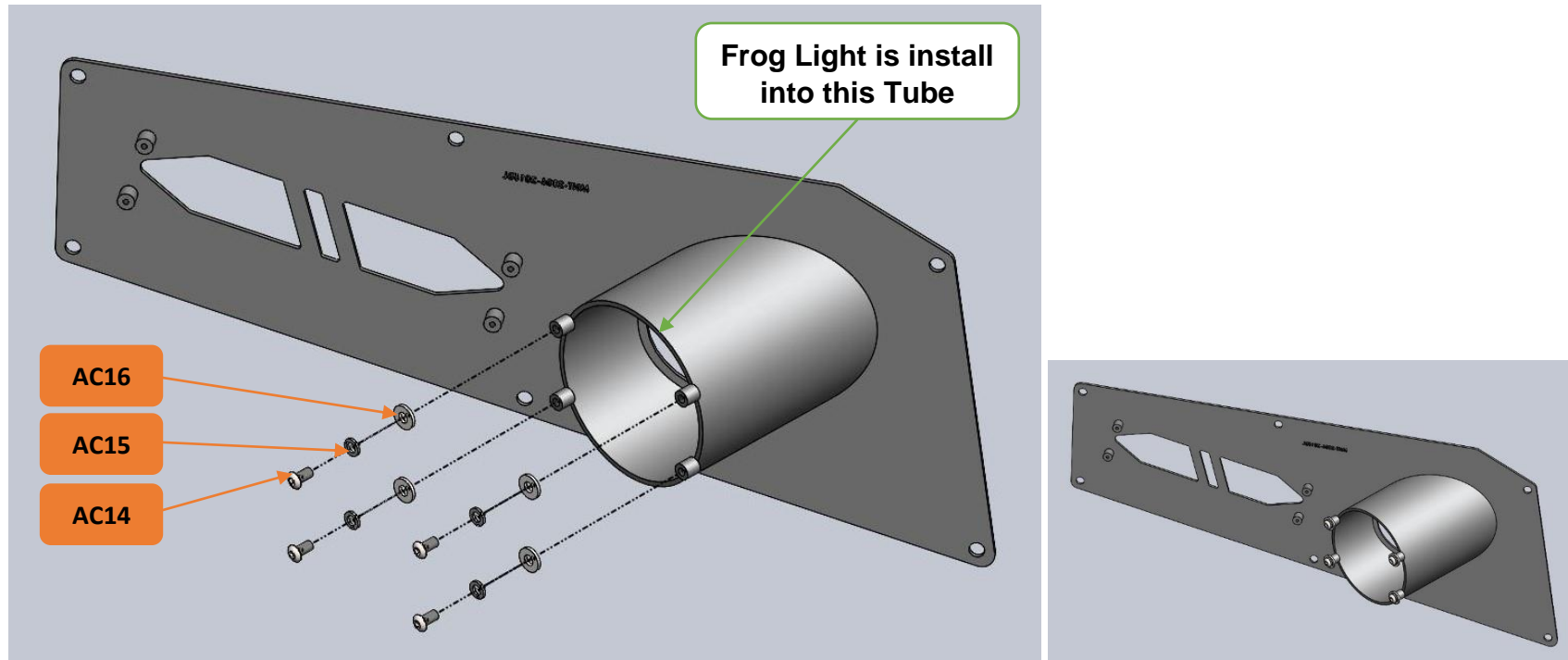

AC31 x 01 pcs : Frog Lights (Pair) with Accessories

AC14 x 08 pcs : M6 x 12mmL x P1 Steel Hex socket (allen Key) & Domed Head Bolt

AC15 x 08 pcs : Steel Spring Washer M6

AC16 x 08 pcs : Steel Flat Washer M6 x 6.6mmID x 15mmOD x 2mmT

Bolt Tightening Torque: 10(Nm)

WI-004-R2

STEP 6.2: Install Indicator Light into Light Panel LH & RH, bolted both side with 8 positions.

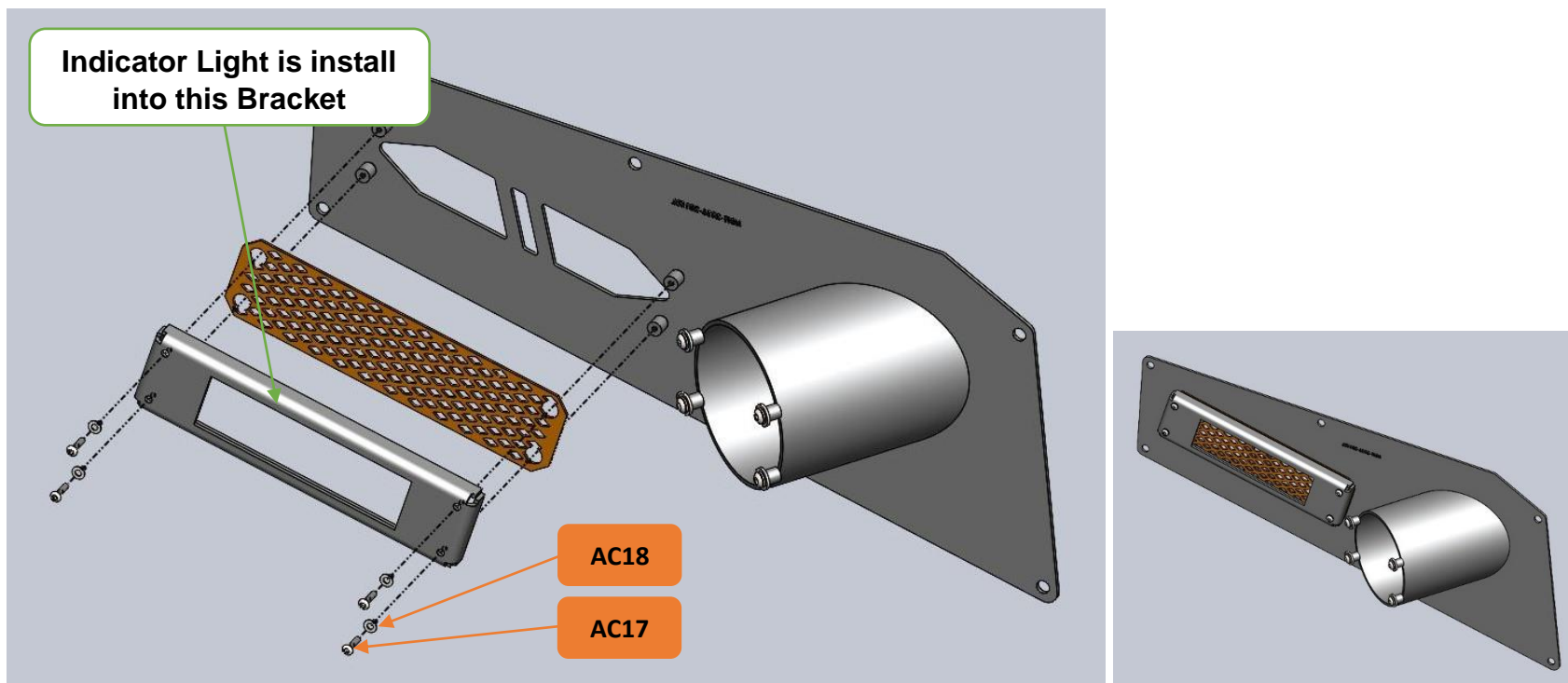

AC32 x 01 pcs : Indicator Lights (Pair)

AC17 x 08 pcs : M4 x 15mmL x P0.7 Hex socket (allen Key) & Domed Head Bolt

AC18 x 08 pcs : Steel Flat Washer M4 x 4.3mmID x 9mmOD x 0.8mmT

Bolt Tightening Torque: 3(Nm)

WI-004-R2

STEP 6.3: Install Light Panel LH & RH, bolted both sides with 12 positions.

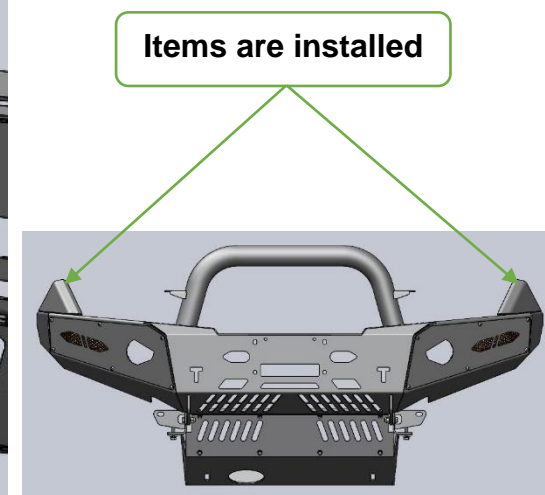
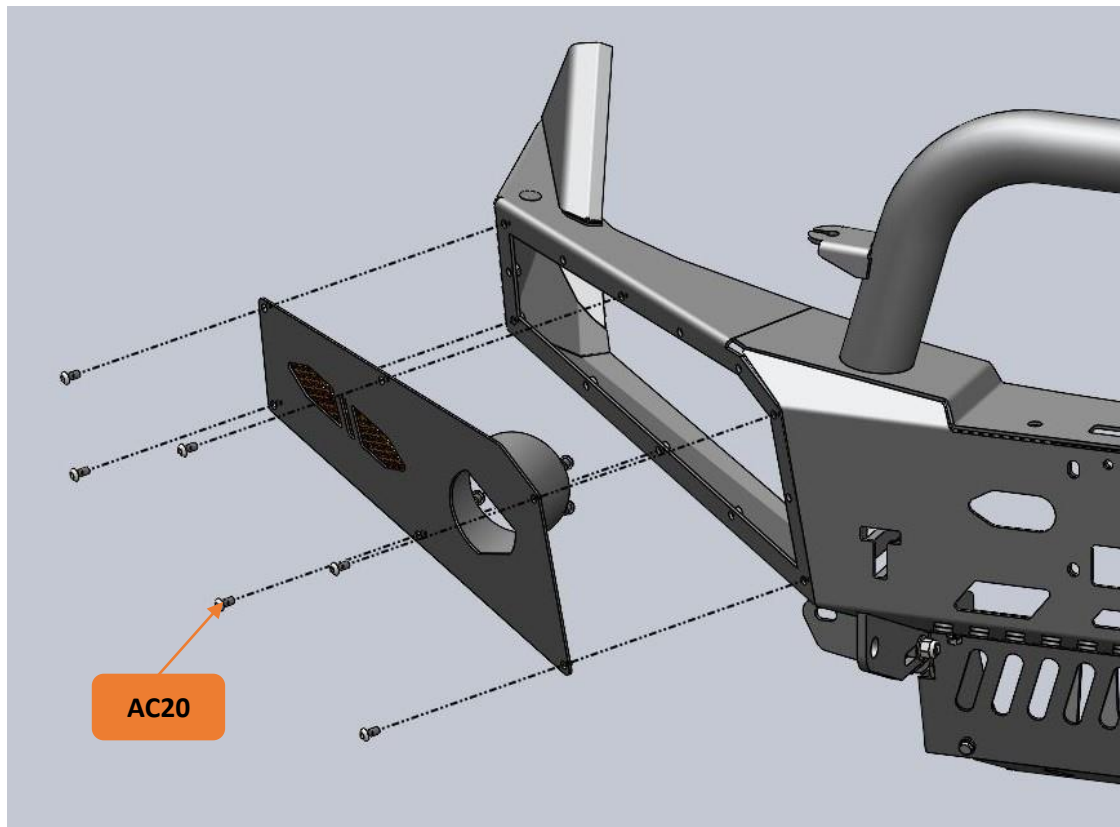

AC20 x 12 pcs : M8 x 16mmL x P1.25 Steel Hex socket (allen Key) & Domed Head Bolt

Bolt Tightening Torque: 15(Nm)

WI-004-R2

STEP 7.1: Install License Bracket into Bull Bar, bolted with 2 positions.

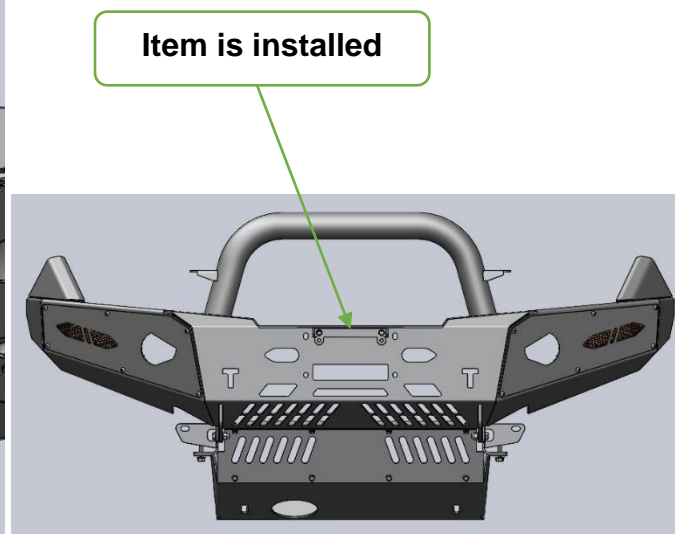
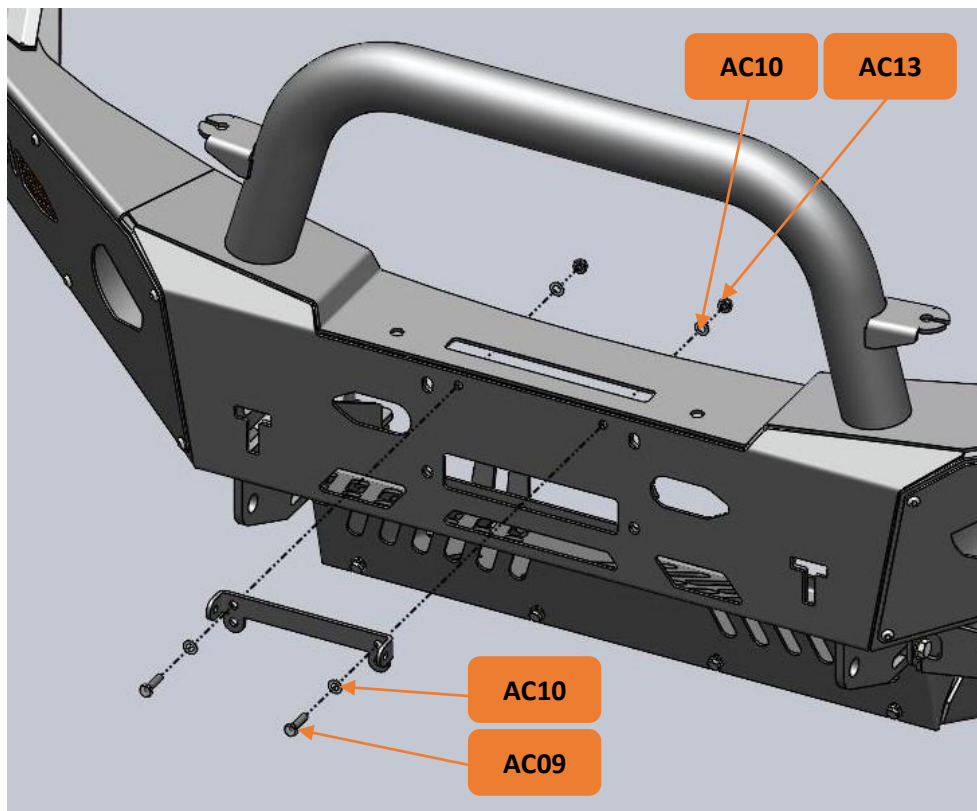

AC09 x 02 pcs : Hex Head Bolt M8 x 30mmL x P1.25 (Full thread) - DIN 933

AC10 x 04 pcs : Steel Flat Washer M8 x 8.4mmID x 17mmOD x 2.5mmT

AC13 x 02 pcs : Nyloc Nut M8 x P1.25

Bolt Tightening Torque: 24(Nm)

WI-004-R2

STEP 7.2: Install License Plate Bracket, bolted with 2 positions.

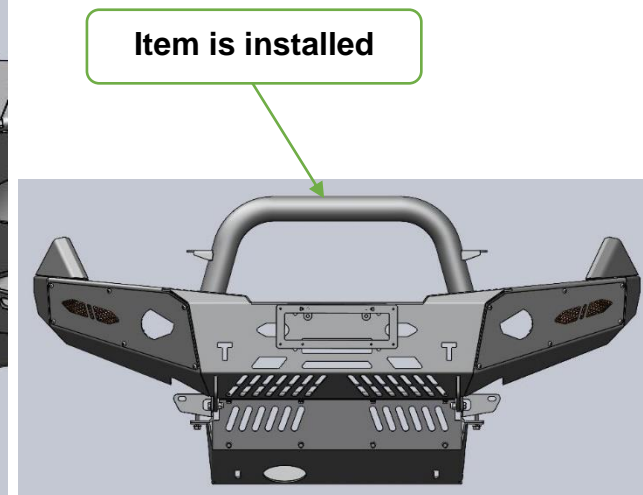
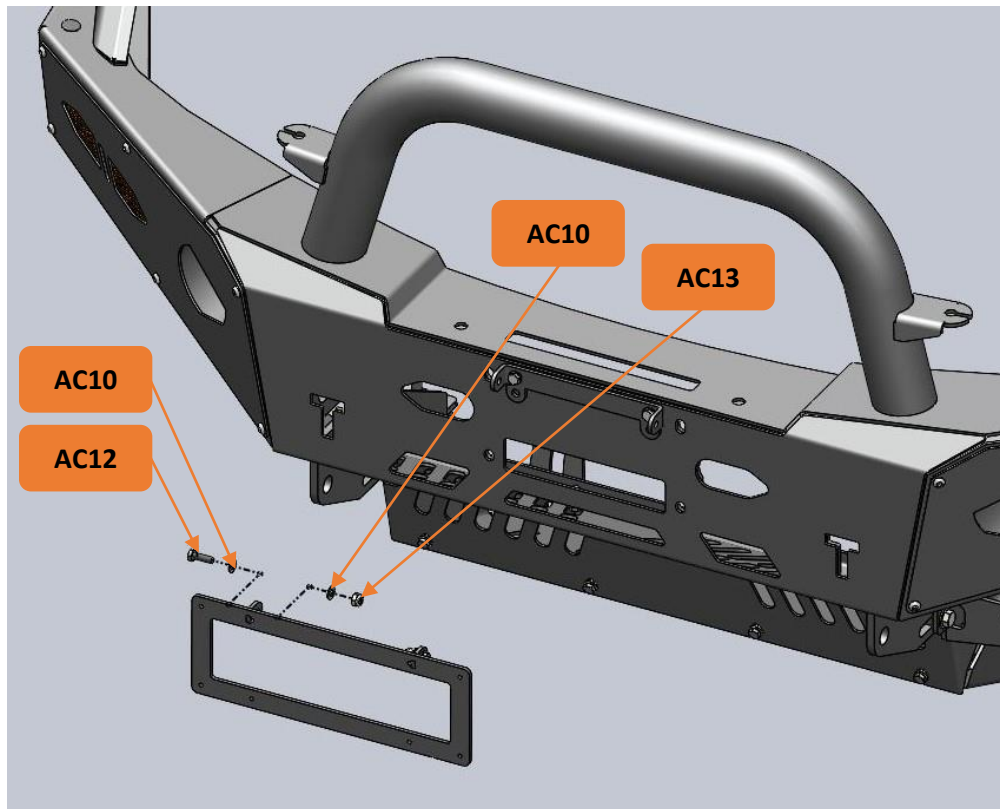

AC10 x 04 pcs : Steel Flat Washer M8 x 8.4mmID x 17mmOD x 2.5mmT

AC12 x 02 pcs : Hex Head Bolt M8 x 25mmL x P 1.25

AC13 x 02 pcs : Nyloc Nut M8 x P1.25

Bolt Tightening Torque: 24(Nm)

WI-004-R2

STEP 7.3: Install License Plate into the Bracket, bolted with 4 positions.

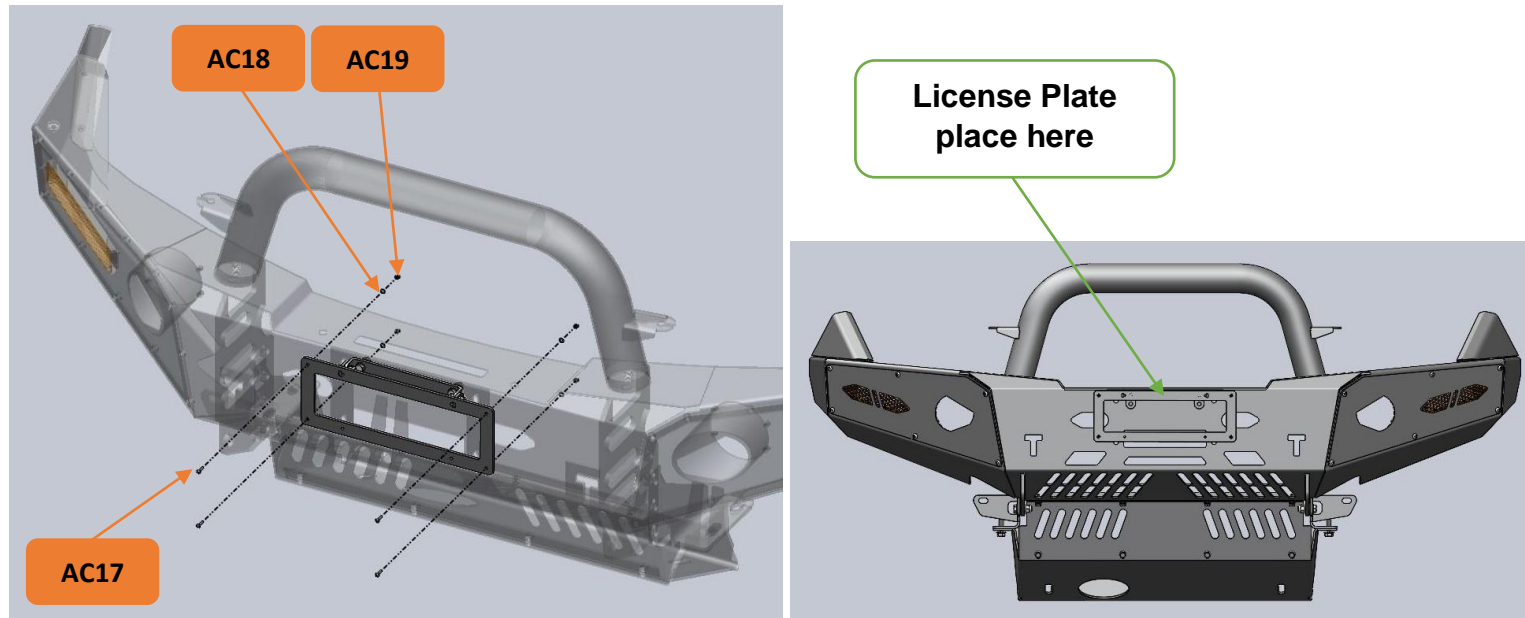

AC17 x 04 pcs : M4 x 15mmL x P0.7 Hex socket (allen Key) & Domed Head Bolt

AC18 x 04 pcs : Steel Flat Washer M4 x 4.3mmID x 9mmOD x 0.8mmT

AC19 x 04 pcs : Nyloc Nut M4 x P0.7

Bolt Tightening Torque: 3(Nm)

Recommendation:

Due to the variation of vehicle chassis some shimming may be required by using the extra washers supplied (**AC04**) to assist in lining up the bar where required.

----- END -----